

Montage- und Betriebsvorschrift

1.0 Beschreibung

Design-Lüftungsventil DLV 100 für Zu- und Abluftbetrieb, DN 100 mm. Mit geschlossener Fassade und integrierter G2-Filtermatte. Einstellbar auf gewünschten Volumenstrom gemäß Kennlinien (Abluft (Abb.1) bzw. Zuluft (Abb.2)).

3.0 Kennlinie DLV 100: Abluft ohne Filter

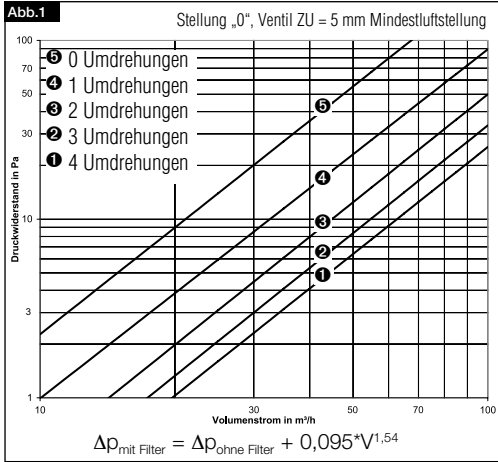

2.0 Bestellumfang

Stück Type Best.-Nr.

1 St. DLV 100 Best.-Nr. 3039

Dichtring DN 100 im Lieferumfang enthalten.

Ersatzluftfilter: Art.-Nr.: 3042 Satz 5 Stück, G2

4.0 Kennlinie DLV 100: Zuluft ohne Filter

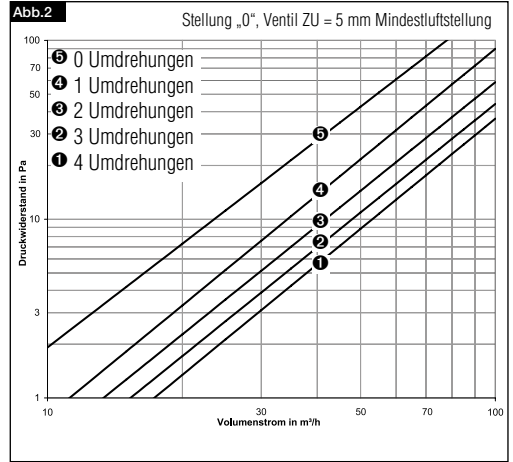

5.0 Explosionsansicht

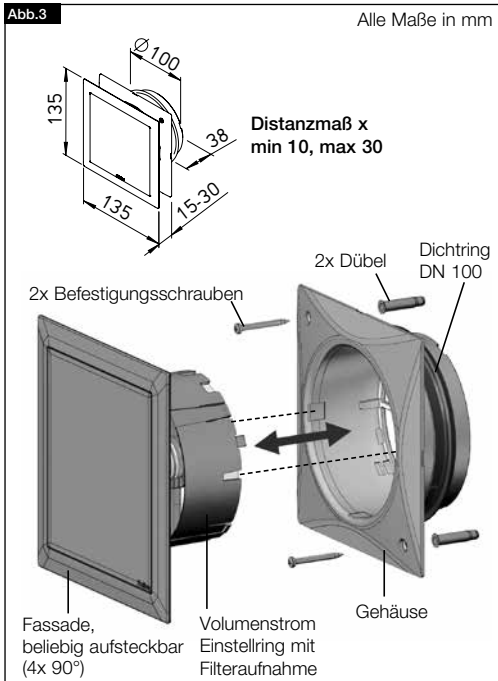

6.0 Filtermontage / Volumenstrom einstellen

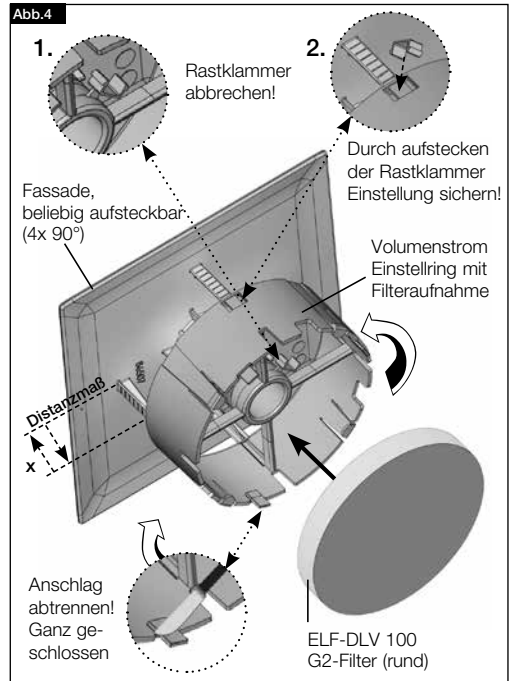



**PREMIUM
PRODUCTS**

DLV 100

Design-Lüftungsventil DLV 100

für Zu- und Abluftbetrieb

DN 100 mm

Artikel: **03039** 001



7.0 Filtertausch

Abb.5



Abb.6



Als Referenz am Gerät griffbereit aufbewahren! Druckschrift-Nr. 86712-001/1217

www.heliosventilatoren.de

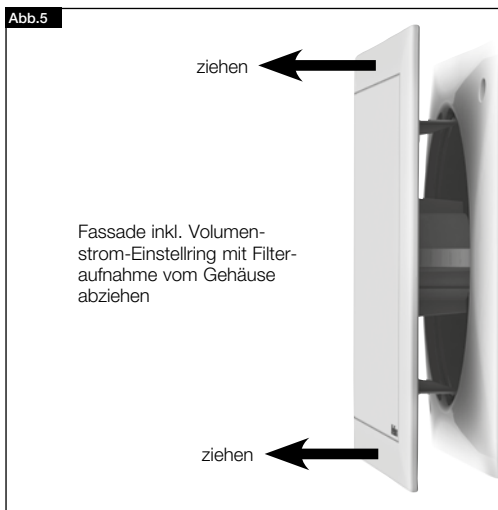
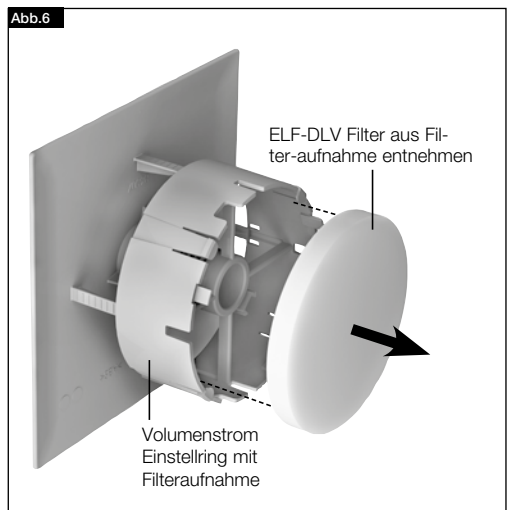
Service / Information

D HELIOS Ventilatoren GmbH & Co. · Lupfenstraße 8 · 78056 VS-Schwenningen

A HELIOS Ventilatoren · Postfach 854 · Siemensstraße 15 · 6023 Innsbruck

F HELIOS Ventilateurs · Le Carré des Aviateurs · 157 av. Charles Floquet · 93155 Le Blanc Mesnil Cedex

CH HELIOS Ventilatoren AG · Tannstraße 4 · 8112 Otelfingen

GB HELIOS Ventilation Systems Ltd. · 5 Crown Gate · Wyncolls Road · Severalis Industrial Park · Colchester · Essex · CO4 9HZ

Installation and Operating Instructions

1.0 Description

Design Ventilation Valve DLV 100 for supply and extract air operation, DN 100 mm. With closed facade and integrated G2 filter mat. Can be adjusted to desired flow rate pursuant to characteristic curves (extract air (Fig.1) or supply air (Fig.2)).

3.0 Characteristic curve DLV 100: extract air w/o filter

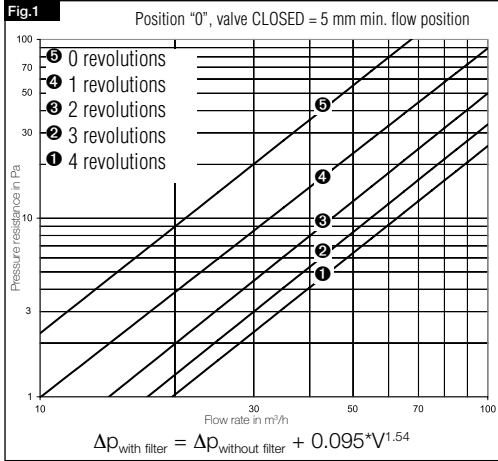

2.0 Scope of delivery

Unit Type Ref. no.

1 unit DLV 100 Ref. no. 3039

Seal ring DN 100 included in scope of delivery.

Replacement filter: Ref. no.: 3042 Set 5 units, G2

4.0 Characteristic curve DLV 100: supply air w/o filter

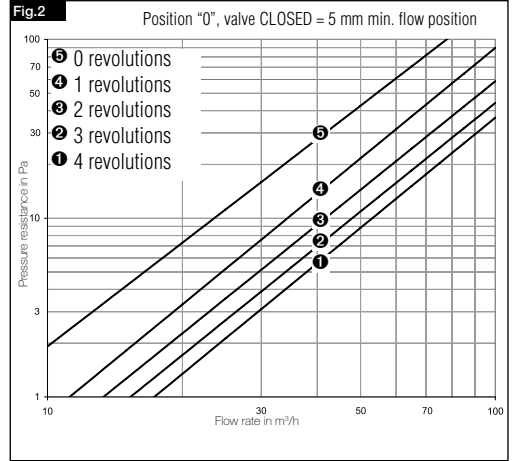

5.0 Exploded view

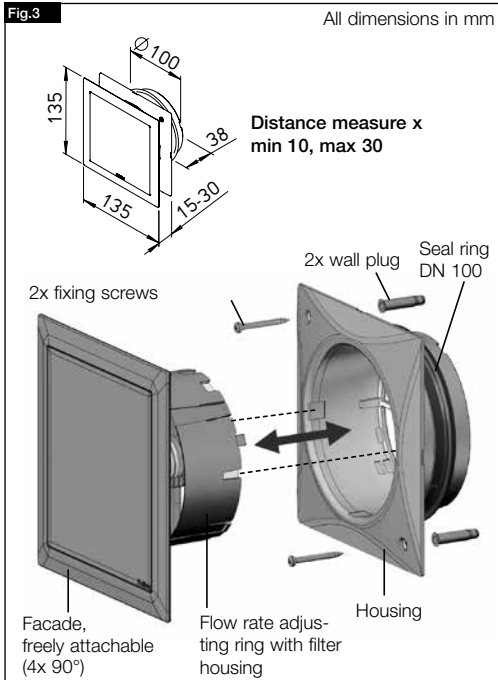

6.0 Filter installation / adjust flow rate

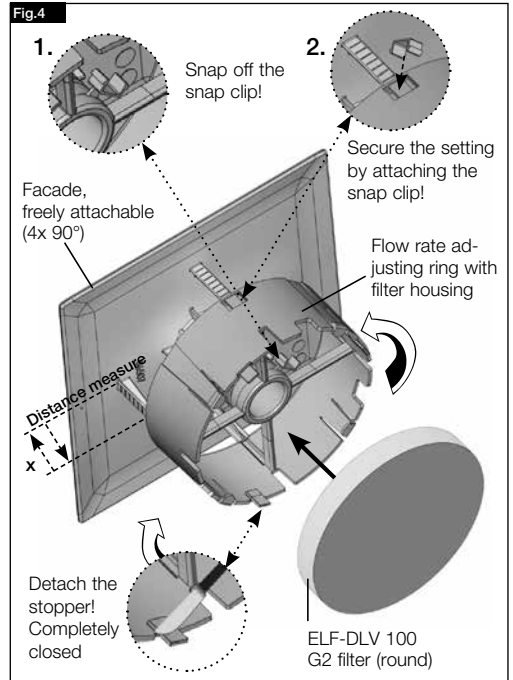



**PREMIUM
PRODUCTS**

DLV 100

Design Ventilation Valve DLV 100
for supply and extract air operation
DN 100 mm

Item: **03039** 001



7.0 Filter change

Fig.5

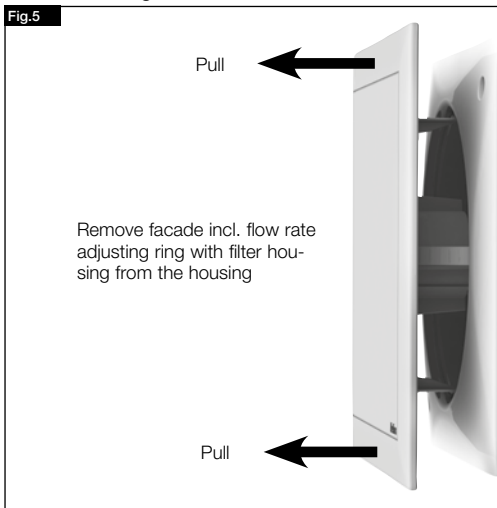
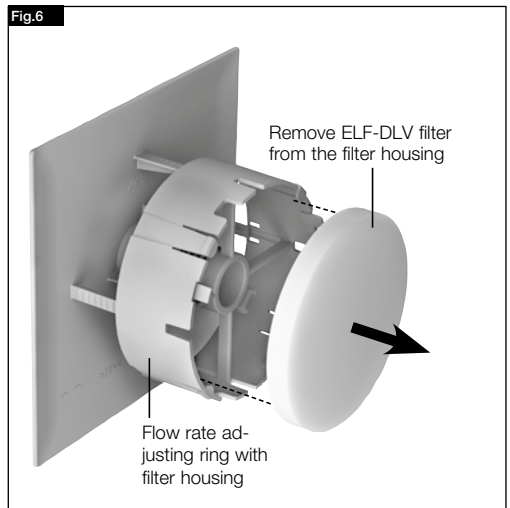

Fig.6



Please keep this manual for reference with the unit! Print no. 86712-001/1217

www.heliosventilatoren.de

Service / Information

D HELIOS Ventilatoren GmbH & Co. · Lupfenstraße 8 · 78056 VS-Schwenningen

A HELIOS Ventilatoren · Postfach 854 · Siemensstraße 15 · 6023 Innsbruck

F HELIOS Ventilateurs · Le Carré des Aviateurs · 157 av. Charles Floquet · 93155 Le Blanc Mesnil Cedex

CH HELIOS Ventilatoren AG · Tannstraße 4 · 8112 Otelfingen

GB HELIOS Ventilation Systems Ltd. · 5 Crown Gate · Wyncolls Road · Severalls Industrial Park · Colchester · Essex · CO4 9HZ

Notice de montage et d'utilisation

1.0 Description

Bouche de ventilation design DLV 100 pour l'extraction et le soufflage, DN 100 mm. Façade pleine et média filtrant G2 intégré. Réglage du débit d'air par simple rotation de la façade (extraction voir courbes Fig. 1 / soufflage, voir courbes Fig. 2.)

3.0 Caractéristique DLV 100 : Extraction sans filtre

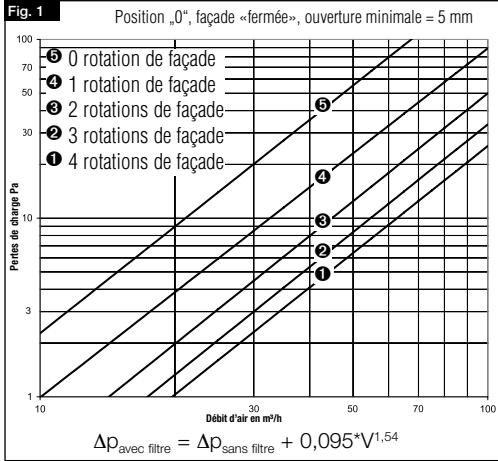

2.0 Volume de commande

Pièce Modèle Réf. N°
 1x DLV 100 Réf. N° 3039

Manchon à joint DN 100 inclus dans la livraison.
 Filtre à air : N° Art : 3042 Set 5 pièces, G2

4.0 Caractéristique DLV 100 : Soufflage sans filtre

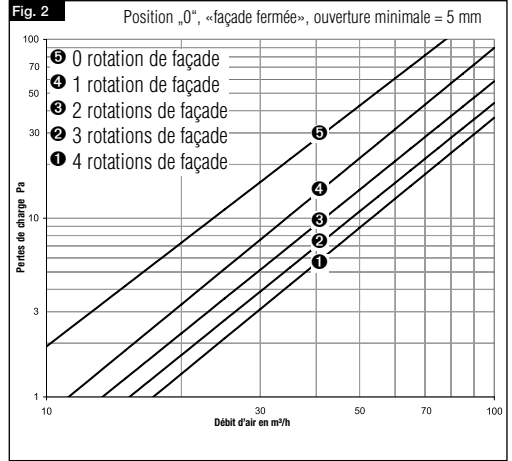

5.0 Vue éclatée

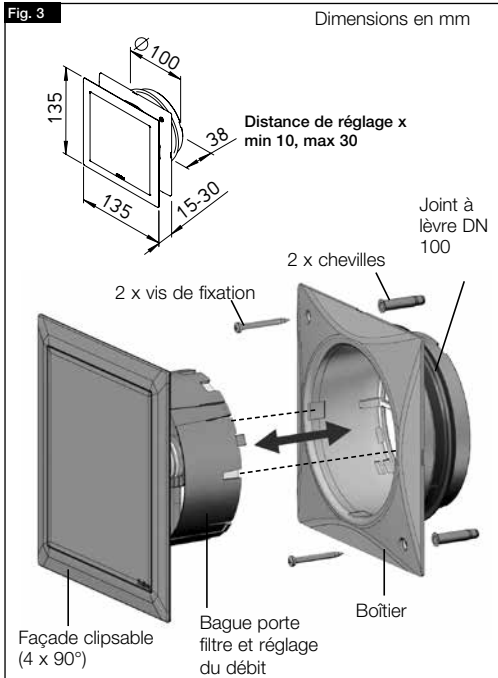

6.0 Montage filtre / Réglage du débit d'air

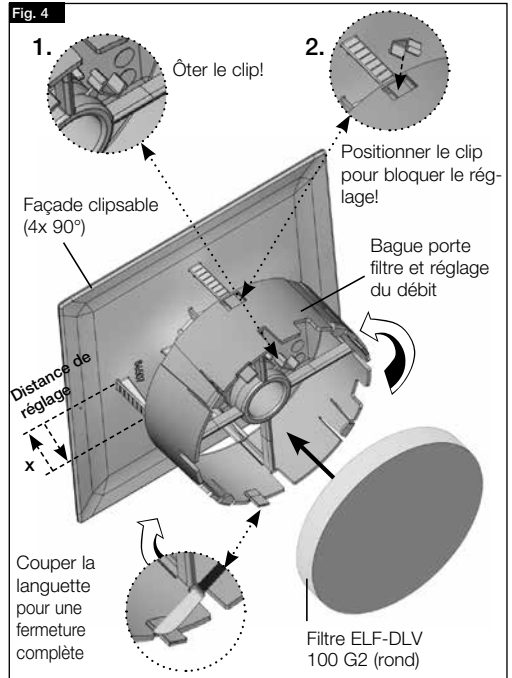



**PREMIUM
PRODUCTS**

DLV 100

Bouche de ventilation design DLV 100
pour l'extraction et soufflage
DN 100 mm

Article: **03039** 001



7.0 Changement de filtre

Fig. 5

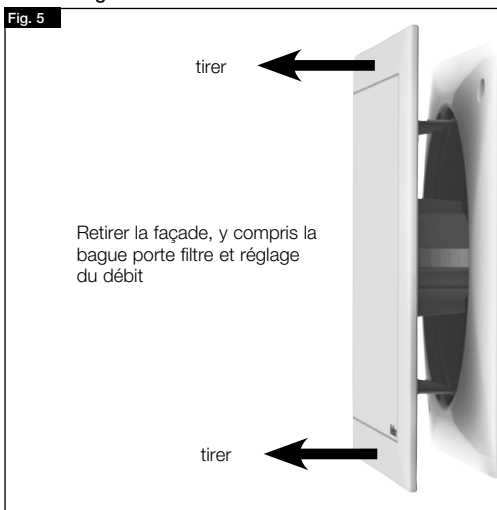
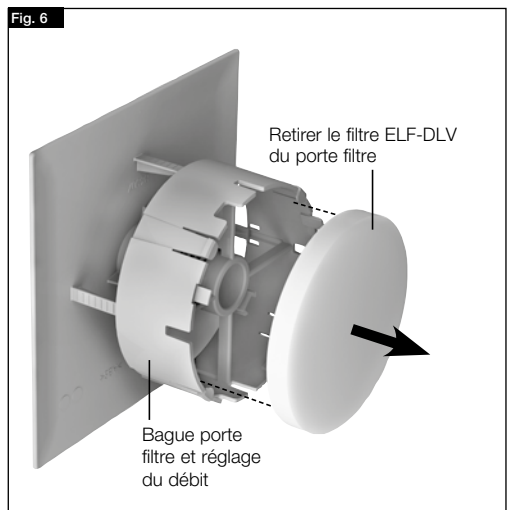

Fig. 6



Conservez la notice à proximité de l'appareil !

N° de Ref. 86712-001/1217

www.heliosventilatoren.de

Service / Information

D HELIOS Ventilatoren GmbH & Co · Lupfenstraße 8 · 78056 VS-Schwenningen

A HELIOS Ventilatoren · Postfach 854 · Siemensstraße 15 · 6023 Innsbruck

F HELIOS Ventilateurs · Le Carré des Aviateurs · 157 av. Charles Floquet · 93155 Le Blanc Mesnil Cedex

CH HELIOS Ventilatoren AG · Tannstraße 4 · 8112 Otelfingen

GB HELIOS Ventilation Systems Ltd. · 5 Crown Gate · Wyncolls Road · Severalis Industrial Park · Colchester · Essex · CO4 9HZ